

Movement by Perfection

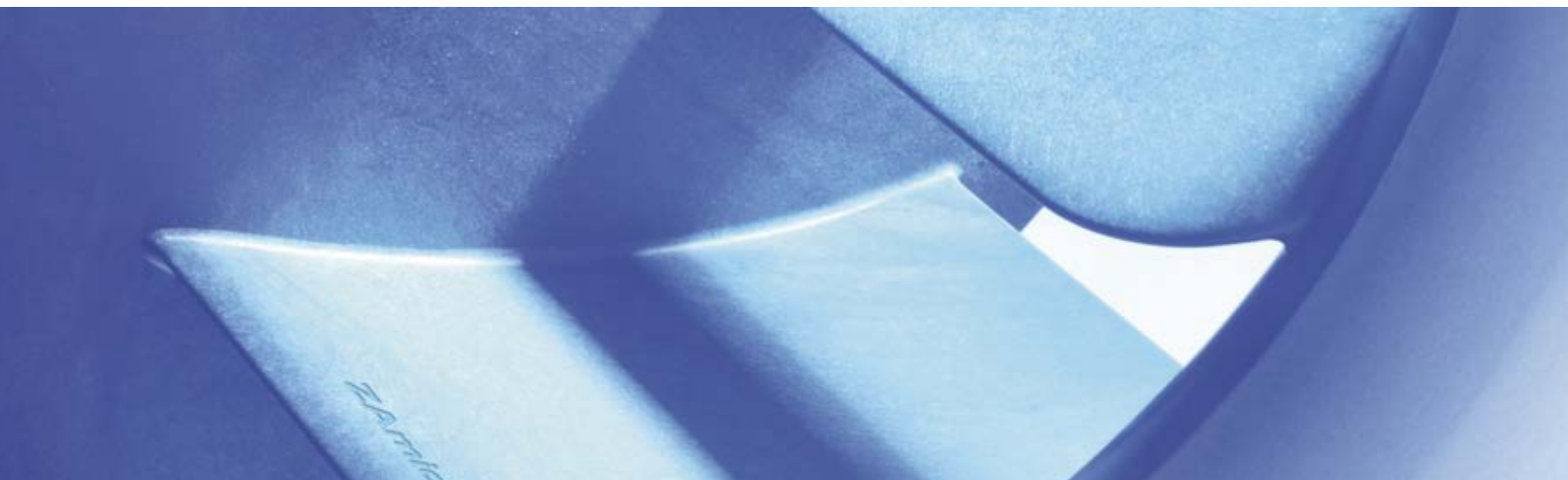

The Royal League in ventilation, control and drive technology



[Product documentation](#)

Type
RH28C-2DK.3F.CR

Article number
175811

Product documentation

Customer

Project
Station One

ZIEHL-ABEGG Subsidiary
Headquarters
ZIEHL-ABEGG SE
Heinz-Ziehl-Straße
74653 Künzelsau
Tel. 07940 16-0
Fax 07940 16-300
info@ziehl-abegg.de
www.ziehl-abegg.de

Type
RH28C-2DK.3F.CR

Article number
175811



Contents

1.	Product specification	3
2.	Characteristic curve	4
3.	Drawing	5
4.	Connection diagram	6
5.	General product and handling description	7

1. Product specification

Technical data

Article number	175811
Type	RH28C-2DK.3F.CR
Designation	Single inlet impeller with backward curved blades.
Rated values	3~230/400V ±10% Δ/Y 50Hz P ₁ 0,62kW 1.80/ 1.05A ΔI=15% 2700/min COSY 0,84 60°C
Electrical connection	Supply cable side, 9x 0,50mm ² x 105cm
Min. operating temperature °C	-40***
Cable quality	Li4G4G-J
Material impeller	Impeller made of ZAMid
Painting impeller	unpainted
Connection diagram	1360-106XA
Installation position	H/Vu
Motor protection	thermal contact
Type of protection	IP54
Thermal class	Thermal class 155
Balancing	6,3
Quality of bearings	ball bearing with long-time lubrication
Special bearing	Ballbearing in special design
Field of application	Conceived for individual application in railways. Bahnbetrieb.
Labelling UL/CSA	zzz_xx
Other	Connecting elements made of stainless steel.
Other	All attaching parts secured with Loctite.
Weight kg	10,00
ErP Data	Efficiency η_{statA} : 47,2 % Efficiency grade: $N_{actual} = 59,8 / N_{target} = 58^*$ *ErP 2013Does not comply with the stipulations of the ErP regulations

*** Occasional operation ≤ -20°C and in consideration of lowest temperature according to product documentation permissible. For cooling applications with continuous operation ≤ -20°C cold design on request.

2. Characteristic curve

Frequency: 50 Hz

Measured with full nozzle without inlet guard grille

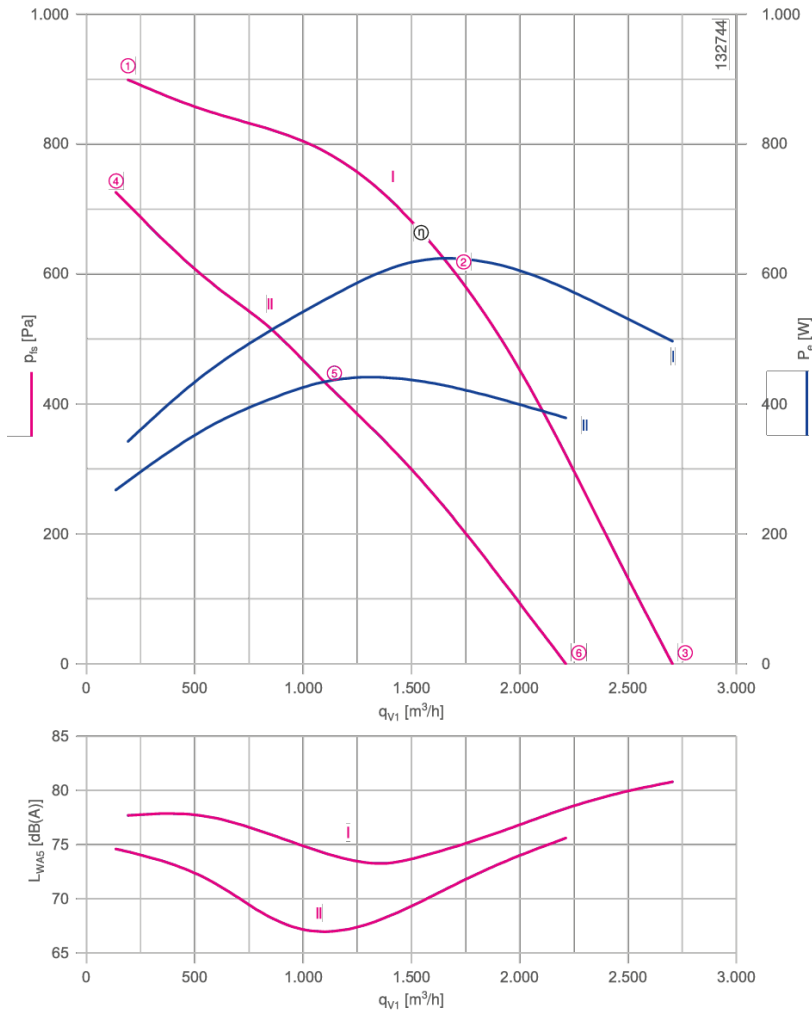

I = 3~400 V D, II = 3~230 V D

Operating point		①	②	③	④	⑤	⑥
Characteristic curve		I	I	I	II	II	II
Connection		Δ	Δ	Δ	Δ	Δ	Δ
Voltage	V	400	400	400	230	230	230
Input power	W	340	620	500	270	440	380
Current	A	0,74	1,05	0,92	0,74	1,20	1,05
Speed	min ⁻¹	2850	2700	2770	2570	2100	2300
Suction side sound power level	dB(A)	78	75	81	75	67	76

3. Drawing

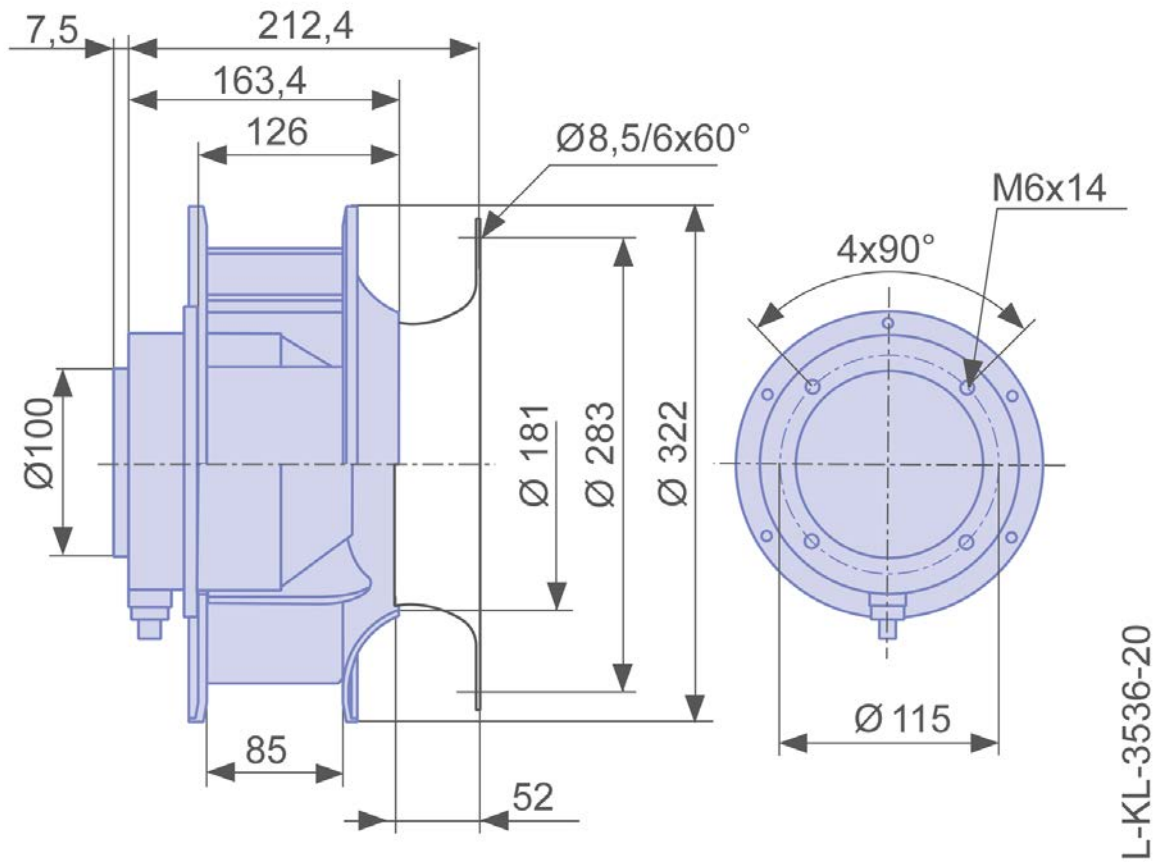

L-KL-3536-20

Dimensions in mm
Shown drawing is just to show the dimensions of the fan.

4. Connection diagram

1360-106XA

3~ motor with one speed and thermostatic switch (if built in).

- U1 brown
- V1 blue
- W1 black
- U2 red
- V2 grey
- W2 orange
- TB white

Δ-connection

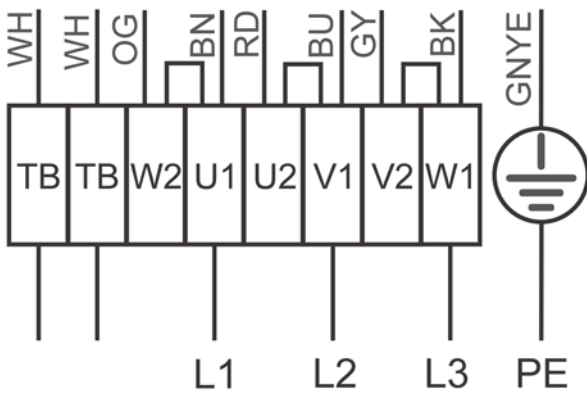

Y-connection

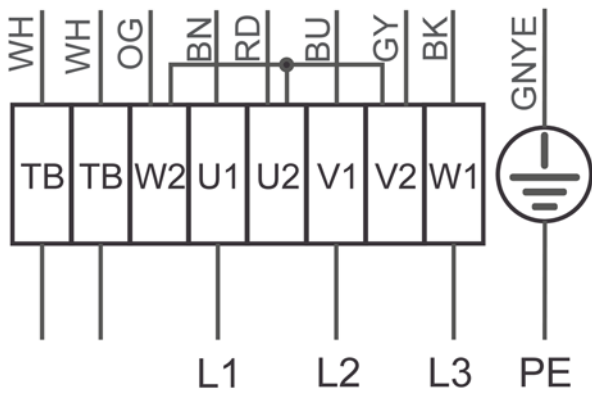

5. General product and handling description

Operating conditions:

The product is designed for conveying non-aggressive, non-explosive, non-fluid, non-adherent, non-abrasive, dust and article-free gaseous media, air-like mixtures und air.

For AC standard fans: The product only works properly with a suitable frequency converter with integrated all-pole active sine filter. The product can be damaged if it's used without an all-pole sine filter between the motor and the frequency converter. Voltage peaks and voltage fluctuations can destroy the product.

To provide error-free operation and prevent damage to the product, the product may only be operated in the admissible operating area according to the above mentioned data sheets and air performance curves.

The formation of small rusty spots during usage in accordance with the product specification and this general product and handling description can occur and does not affect the functionality of the product.

The product must never be used in obviously damaged condition.

Continuous intentional change of direction of rotation is not allowed.

Reverse current braking is not allowed.

Assembly:

The assembly has to meet the requirements of the assembly instructions to enable error-free operation.

Commissioning:

Commissioning should be done by appropriately qualified technical personnel according to the specifications in the operating and assembly instructions.

Documentation:

In case of defective parts or products or in case of any warranty, it may be necessary to analyse the root cause of the defect.

Therefore, ZIEHL-ABEGG may ask for documentation of proper life-cycle handling according to the instructions and the general product and handling description. ZIEHL-ABEGG may ask for appropriate documentation records in order to assess root cause of the defect.

Maintenance and inspection:

Any maintenance and inspection should be carried out in accordance with the operating and assembly instructions.

Packaging, storage and transport:

Packaging, storage and transport should be carried out in accordance with the operating and assembly instructions to avoid product damage.

Condensate formation inside the packaging can lead to formation of rust.

Long-term storage of the product should take place in dry environment. Shocks during storage can lead to product damage. Bearing streams should be avoided.

Spare parts:

In all warranty cases repairs has to be carried out by ZIEHL-ABEGG. In all other cases spare parts shall meet the specifications of the original installed parts to ensure error-free operation. Use of original ZIEHL-ABEGG spare parts is recommended.

Specific application/Intended purpose:

Suitability of the product for the specific application is beyond control of ZIEHL-ABEGG. Therefore, customer is necessarily obliged to test and approve the product in the application. ZIEHL-ABEGG will not warrant or guarantee any suitability of the product for customer's specific application or intended purpose.

The Royal League Die Königsklasse



The Royal League in ventilation, control and drive technology

Intelligent control technology for any application

ZIEHL-ABEGG system capabilities:

Everything from a single source – perfectly matched for optimal performance

Please contact us. We would be pleased to design an individual solution for your requirements.

We would like to welcome you on our worldwide exhibitions. Please find our next exhibitions [here](#).